

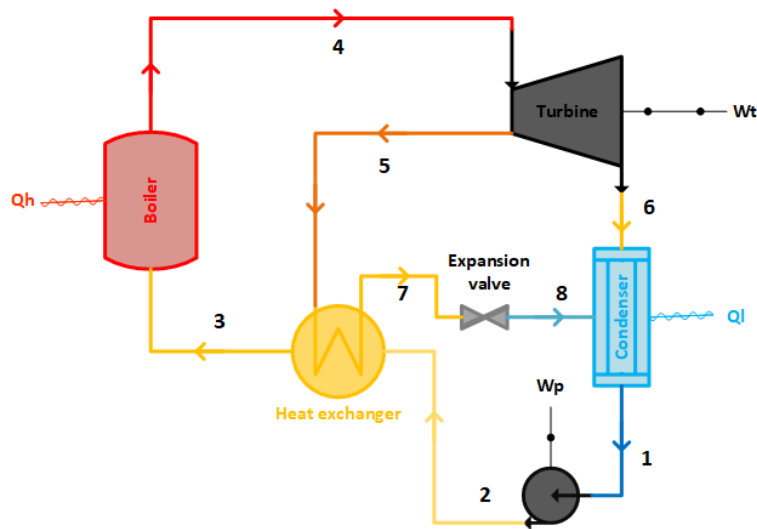

PROJECT

DESCRIPTION

Figure shown below is a steam power plant operating on a Rankine cycle. To be specific, this is a detailed version of a heat engine, which obtains heat (Q_H) and produces work (W_{net}), and finally, discharges some heat (Q_L) elsewhere. The plant maintains the turbine inlet at 10Mpa and 600°C ; and operates the condenser at 65kPa . Steam is extracted from the turbine to serve the mixing chamber, which discharges into the condenser after being throttled to condenser pressure. Assume the heat exchanger is ideal and water is saturated before going into the pump and the expansion valve. We want this power plant to produce 27MW net power. Water flow through the system with a mass flow rate of 25kg/s . The Isentropic efficiency of the pump is 75% . The turbine is reversible. The boiler heat is provided by a furnace operating at 650°C . The condenser is rejecting heat to the ocean at a depth of 10m where Temperature is about 15°C . You can assume the inlet to the pump is saturated liquid.



1. Draw the T-s diagram of the power plant with the knowledge of each element in the system.
 2. With the help of (1), simulate the cycle in EES and report the following parameters:

Heat transfer in the boiler	Heat rejected by the condenser	Work produced by turbine
Work needed for pump	Mass fraction of the turbine exits	Heat exchanged in the heat exchanger
P,T,h,v,s, and x of all states	Temperature-drop in the valve	Efficiency of the cycle
 3. Know, draw the T-s diagram using EES and compare it with your own.
 4. Plot the variations of Q_H & Q_L with respect to the condenser pressure spanning from 65 to 115 kpa . Report the range in which Q_H & Q_L vary, and show it on the plot.
 5. Plot the variations of the efficiency with respect to the condenser pressure spanning from 65 to 115 kpa . Assume there is a 2^{nd} order polynomial relation between the efficiency and the condenser pressure. Fit a curve to the data and use the relation to calculate the efficiency when the pressure is 80 kpa .
 6. If the possible pressure range for the condenser is 5 to 20 kpa , what would be the most suitable pressure?
- The project should be done individually. Upload the report and EES code (.EES file) in a RAR format to the eLearn system.